

Dimensions of internal unit

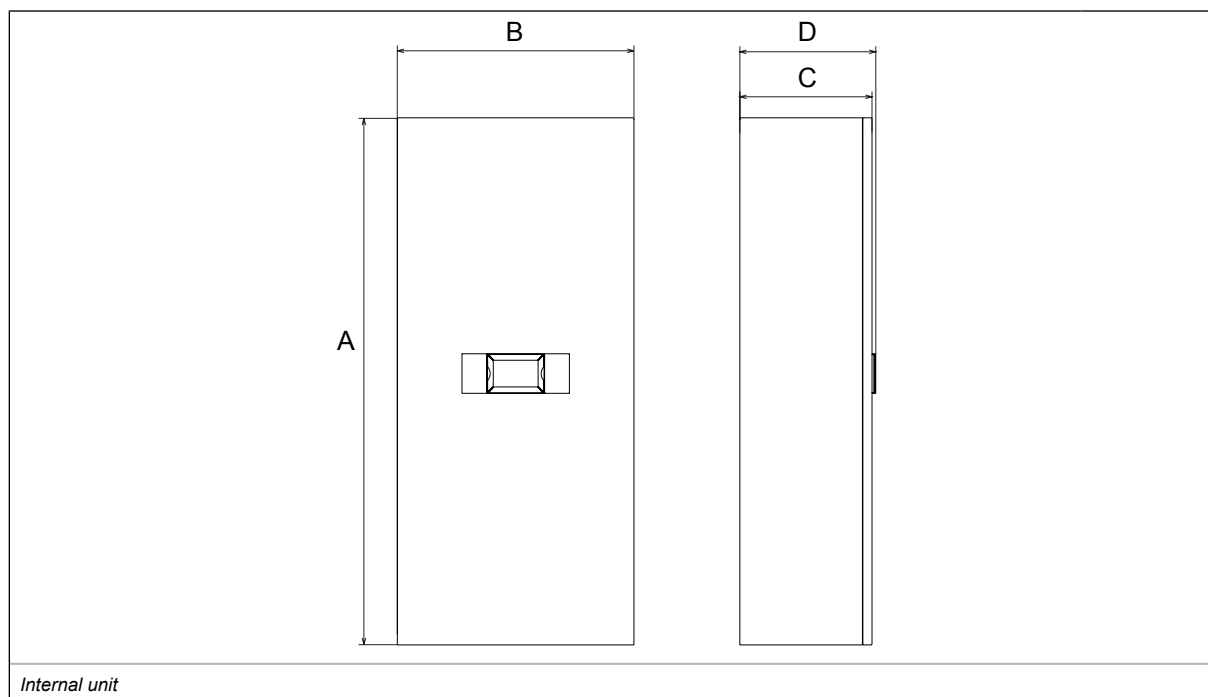

		SHERPA AQUADUE 7	SHERPA AQUADUE 11	SHERPA AQUADUE 13	SHERPA AQUADUE 13T	SHERPA AQUADUE 16	SHERPA AQUADUE 16T
Internal unit		SMALL 599510A			BIG 599506A		
A	mm	1116	1116	1116	1116	1116	1116
B	mm	500	500	500	500	500	500
C	mm	280	280	280	280	280	280
D	mm	288	288	288	288	288	288
Standard weight	kg	70	70	72	72	72	72
<i>Dimensions and weight values of the internal unit</i>							

Dimensions of external unit

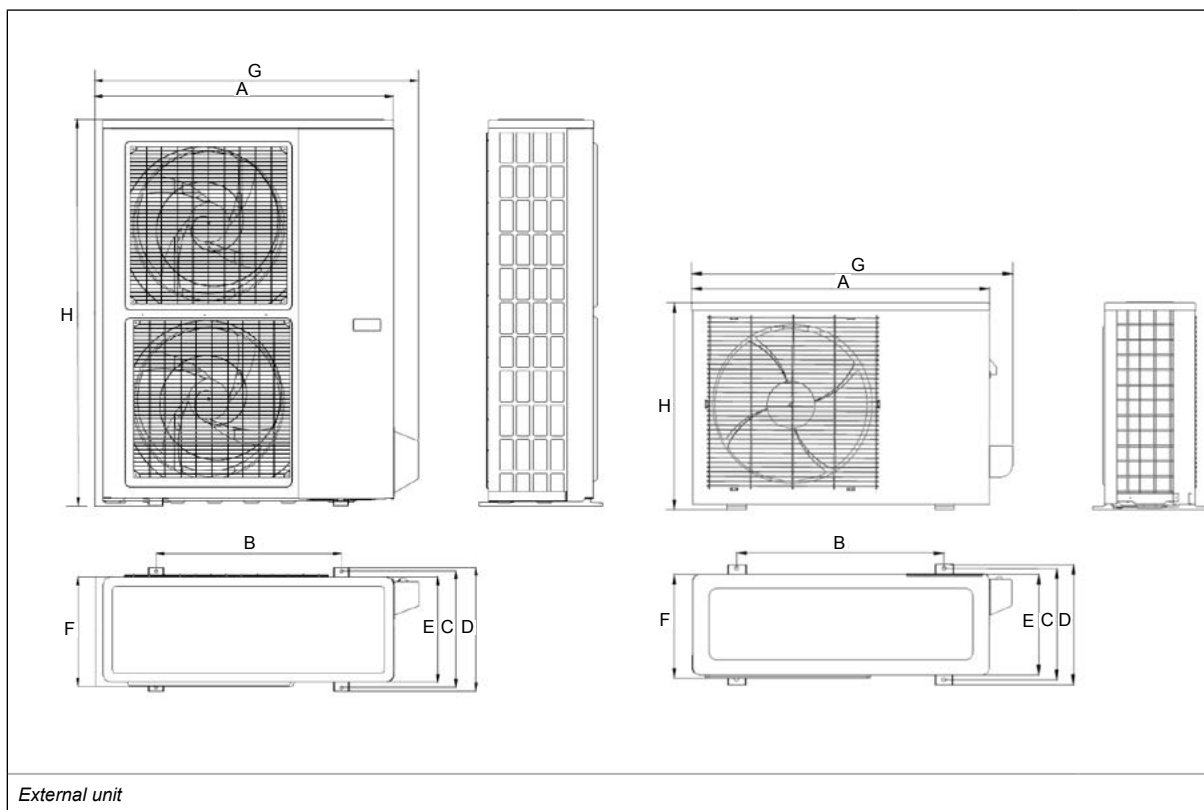

		SHERPA AQUADUE 7	SHERPA AQUADUE 11	SHERPA AQUADUE 13	SHERPA AQUADUE 13T	SHERPA AQUADUE 16	SHERPA AQUADUE 16T
External unit		OS CEBSH24EI	OS CEBCH36EI	OS CEINH48EI	OS CETNH48EI	OS CEINH60EI	OS CETNH60EI
		SINGLE-FAN			DUAL-FAN		
A	mm	847	990	938	938	938	938
B	mm	563	622	633	633	633	633
C	mm	340	368	404	404	404	404
D	mm	360	398	448	448	448	448
E	mm	315	340	370	370	370	370
F	mm	330	350	392	392	392	392
G	mm	917	1060	1008	1008	1008	1008
H	mm	700	950	1369	1369	1369	1369
Weight	kg	58	82	99	102	99	107
<i>Dimensions and weight values of the external unit</i>							

Dimensions of S1 external unit

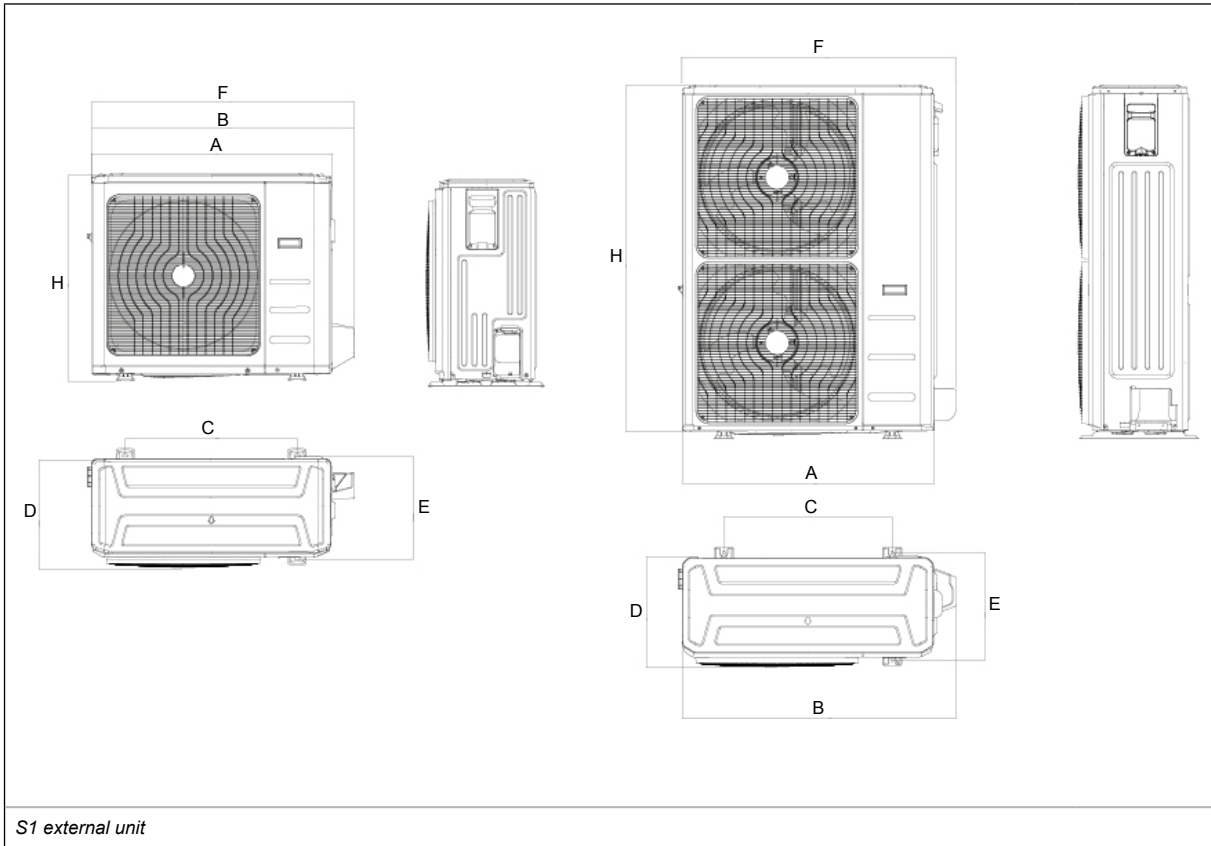

		SHERPA AQUADUE 7	SHERPA AQUADUE 11	SHERPA AQUADUE 13	SHERPA AQUADUE 13T	SHERPA AQUADUE 16	SHERPA AQUADUE 16T
S1 external unit		OS CESHH24EI	OS CESHH36EI	OS CESHH48EI	OS CESTH48EI	OS CESHH60EI	OS CESTH60EI
		SINGLE-FAN			DUAL-FAN		
A	mm	845	946	952	952	952	952
B	mm	914	1030	1045	1045	1045	1045
C	mm	540	673	634	634	634	634
D	mm	363	410	415	415	415	415
E	mm	350	403	404	404	404	404
F	mm	915	1036	1032	1032	1032	1032
H	mm	702	810	1333	1333	1333	1333
Weight	kg	49	67	95	108	95	113
<i>Dimensions and weight values of the S1 external unit</i>							