

NEW

SHERPA AQUADUE

S3



Compatible with:
SIOS CONTROL

Multi-purpose split heat pumps, suspended and tower versions



DHW AND COMFORT AT THE SAME TIME

The two interconnected refrigerator cycles allow the decoupling of the heating/cooling from the DHW production, enabling them to operate in parallel, avoiding thus interruptions in the domestic comfort supply.



DOMESTIC HOT WATER UP TO 75°C

The storage of DHW at high temperature makes it possible to reduce the volume of the storage tank by up to 30%, and to avoid energy-intensive consumption of the anti-Legionnaire's disease cycles, since they are normally carried out by the use of electric heating elements.



LOW GWP GAS

All power sizes use the R32 refrigerant, characterised by greater efficiency and a greenhouse effect reduced by almost 70% (compared to R410A).



FEATURES

- **Inverter air-water heat pump**
- **Energy efficiency class** in average climate heating up to: A+++ (35°C) and A++ (55°C)
- **Powers available:** 10 powers with refrigerant R32 single-phase (4-6-8-10-12-14-16 kW) and three-phase (12-14-16 kW).
- **Production of DHW** (Domestic Hot Water) at high temperature, up to 75°C.
- **DHW management:** a water/water heat pump unit integrated in the internal unit supplies domestic hot water at high temperature regardless of the external climatic conditions.
- **Absolute continuity availability of DHW:** guaranteed by the redundancy of the double refrigeration circuit
- **Anti-legionella cycles that can be avoided** using the high temperature refrigeration cycle.
- **Double stage electric heating elements as standard:** activation of single or double heating element to support the heat pump by means of a simple electronic control configuration. Each stage is activated according to the actual need for thermal power, in order to optimise electricity consumption (supplied disabled by default).

- **Configurable set points:** two set points in cooling. Three set points in heating (one of which for DHW): the set points can also be selected via remote contact.
- **Holiday** and weekly programmer: heating/cooling, DHW, night-time.
- **Climatic curves** with external air temperature probe: two curves available, one for cooling and one for heating. The climatic curves are used to vary the temperature of the water supplying the system according to the external climatic conditions, adjusting the thermal needs of the building, in order to achieve energy savings.
- **Refrigerant gases:** R32* for the reversible circuit dedicated to air conditioning and R134a** for the high temperature circuit dedicated to the production of DHW.
- **Built-in 150 L high efficiency storage tank** (tower version) with an exchange battery surface equal to 1.5 m².
- **Operating limits:** down to -25°C, +43°C (see technical manuals for details).
- **Integrated heating cable** to prevent freezing of water in the tray for sizes 12-14-16 and 12T-14T-16T. The heating cable intervenes during machine defrost operations or when the ambient air is below -7°C and cuts out when it exceeds 4°C (85W power consumption).

AQUADUE TECHNOLOGY

HEATING MODE

+DHW at high temperature

Production of DHW guaranteed regardless of the outside temperature for optimal operation all year round, not guaranteed by traditional heat pumps.

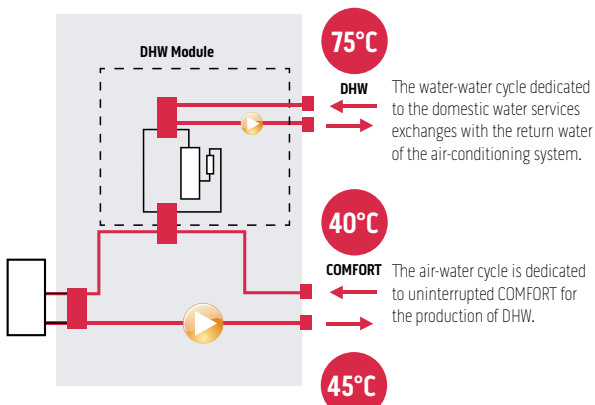

COOLING MODE

+DHW at a high temperature with energy recovery

The energy normally dissipated outside is recovered and used to produce DHW up to 75°C.

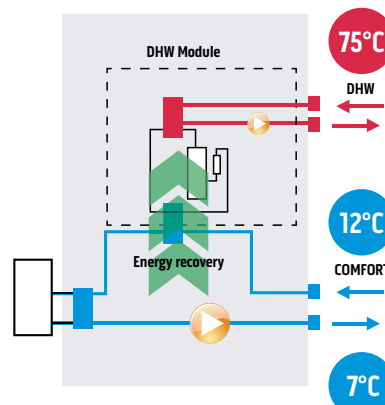

* Equipment not hermetically sealed containing fluorinated gases with an equivalent GWP of 675 (R32)

** Non-hermetically sealed equipment containing fluorinated gas with GWP equivalent 1430

LAYOUT, DIMENSIONS, WEIGHT

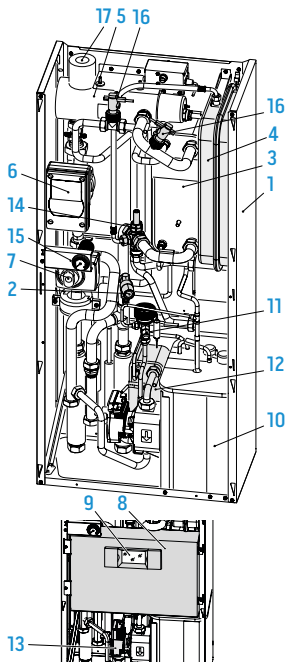

1. Support structure
2. 3 bar safety valve
3. Main circuit heat exchanger
4. Expansion tank
5. Post-heating electric heating element manifold
6. Air conditioner circuit circulation pump
7. 3-way valve
8. Electrical panel assembly
9. Touchscreen display
10. Compressor
11. Expansion valve
12. DHW circuit heat exchangers
13. DHW circuit circulation pump
14. DHW circuit evaporator water flow rate regulator
15. Water circuit pressure gauge
16. Flow switches
17. Automatic vent valves

Suspended indoor units

		SMALL				BIG					
		4	6	8	10	12	14	16	12T	14T	16T
A	mm	500	500	500	500	500	500	500	500	500	500
B	mm	280	280	280	280	280	280	280	280	280	280
C	mm	288	288	288	288	288	288	288	288	288	288
H	mm	1116	1116	1116	1116	1116	1116	1116	1116	1116	1116
Weight	kg	70	70	70	70	70	70	70	70	70	70

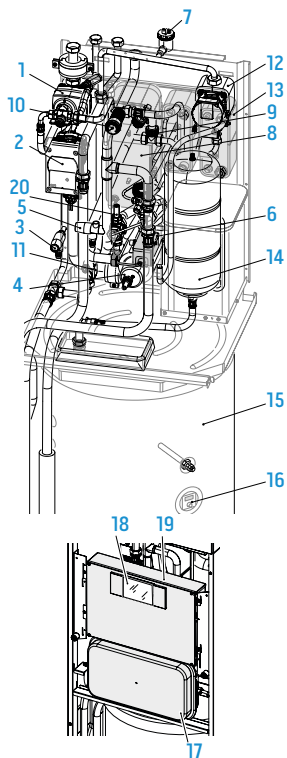
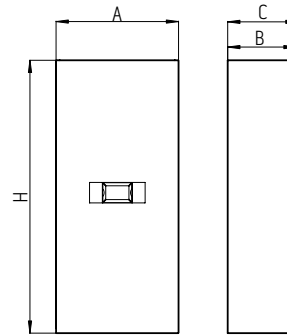

1. 3-way valve
2. Air conditioner circuit circulation pump
3. Safety valves (DHW circuit 6 bar)
4. Post-heating electric heating element manifold
5. Safety valves air conditioner circuit 3 bar
6. Electric heating elements safety thermostats
7. Automatic air vent valve
8. Air conditioner circuit heat exchanger
9. Flow switches
10. Air conditioning circuit pressure gauge
11. DHW thermostatic accumulators
12. DHW circuit circulation pump
13. DHW circuit heat exchangers
14. DHW circuit expansion tank
15. DHW tank
16. Anode tester
17. Air conditioner circuit expansion tank
18. Touch screen display
19. Electrical panel assembly
20. DHW circuit evaporator water flow rate regulator

Tower indoor units

		SMALL				BIG					
		4	6	8	10	12	14	16	12T	14T	16T
A	mm	600	600	600	600	600	600	600	600	600	600
B	mm	600	600	600	600	600	600	600	600	600	600
H	mm	1980	1980	1980	1980	1980	1980	1980	1980	1980	1980
Weight	kg	171	171	171	171	171	171	171	171	171	171

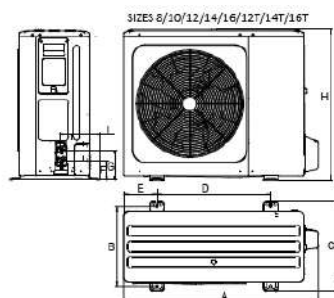
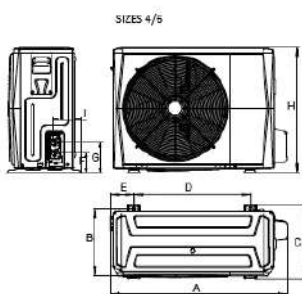
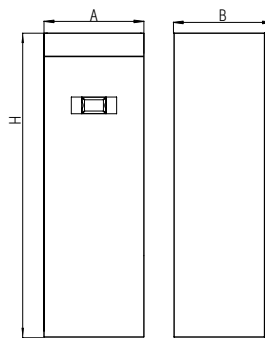

Outdoor units

		4	6	8	10	12	14	16	12T	14T	16T
		A	mm	1008	1008	1118	1118	1118	1118	1118	1118
B	mm	375	375	456	456	456	456	456	456	456	456
C	mm	426	426	523	523	523	523	523	523	523	523
D	mm	663	663	656	656	656	656	656	656	656	656
E	mm	134	134	191	191	191	191	191	191	191	191
F	mm	110	110	110	110	110	110	110	110	110	110
G	mm	170	170	170	170	170	170	170	170	170	170
H	mm	712	712	865	865	865	865	865	865	865	865
I	mm	160	160	230	230	230	230	230	230	230	230
Weight	kg	58	58	77	77	96	96	96	112	112	112

SINGLE-PHASE R32 TECHNICAL DATA

				4			6			8			10				
ODU Sherpa S3 E				02284			02285			02286			02287				
IDU Sherpa Aquadue S3 E				02296			02296			02296			02296				
IDU Sherpa Aquadue Tower S3 E				02298			02298			02298			02298				
Compressor frequency				Minimum	Nominal	Maximum	Minimum	Nominal	Maximum	Minimum	Nominal	Maximum	Minimum	Nominal	Maximum		
PUNCTUAL PERFORMANCE	Heating power	a7/6 - w30/35	(a)	kW	2,42	4,25	5,66	3,53	6,20	8,26	4,73	8,30	11,05	5,70	10,0	13,32	
	COP	a7/6 - w30/35	(a)	W/W	-	5,15	-	-	5,00	-	-	5,20	-	-	5,00	-	
	Heating power	a2/1 - w30/35	(b)	kW	2,54	4,45	5,93	3,13	5,50	7,32	4,05	7,10	9,46	4,67	8,20	10,92	
	COP	a2/1 - w30/35	(b)	W/W	-	4,05	-	-	3,95	-	-	4,10	-	-	4,05	-	
	Heating power	a-7/-8 - w30/35	(c)	kW	2,74	4,80	6,39	3,48	6,10	8,12	4,05	7,10	9,46	4,70	8,25	10,99	
	COP	a-7/-8 - w30/35	(c)	W/W	-	3,15	-	-	3,05	-	-	3,25	-	-	3,15	-	
	Heating power	a-15/-16 - w30/35	(d)	kW	1,75	3,07	4,09	2,15	3,77	5,02	3,31	5,80	7,72	3,48	6,10	8,12	
	COP	a-15/-16 - w30/35	(d)	W/W	-	2,88	-	-	2,83	-	-	2,98	-	-	3,01	-	
	Heating power (fancoils)	a7/6 - w40/45	(f)	kW	2,48	4,35	5,79	3,62	6,35	8,46	4,67	8,20	10,92	5,70	10,00	13,32	
	COP (fancoils)	a7/6 - w40/45	(f)	W/W	-	3,80	-	-	3,75	-	-	3,95	-	-	3,80	-	
	Heating power (fancoils)	a2/1 - w40/45	(g)	kW	2,91	5,10	6,79	3,31	5,80	7,72	4,22	7,40	9,86	4,47	7,85	10,45	
	COP (fancoils)	a2/1 - w40/45	(g)	W/W	-	3,00	-	-	3,00	-	-	3,25	-	-	3,20	-	
	Heating power (fancoils)	a-7/-8 - w40/45	(h)	kW	2,45	4,30	5,73	3,08	5,40	7,19	3,76	6,60	8,79	4,19	7,35	9,79	
	COP (fancoils)	a-7/-8 - w40/45	(h)	W/W	-	2,35	-	-	2,40	-	-	2,55	-	-	2,55	-	
	Heating power (fancoils)	a-15/-16 - w40/45	(i)	kW	1,52	2,66	3,54	1,86	3,27	4,35	2,87	5,04	6,71	3,03	5,31	7,07	
	COP (fancoils)	a-15/-16 - w40/45	(i)	W/W	-	2,02	-	-	1,98	-	-	2,32	-	-	2,34	-	
	Cooling power	a35 - w23/18	(l)	kW	2,41	4,50	5,52	3,51	6,55	8,03	4,50	8,40	10,30	5,36	10,00	12,27	
	EER	a35 - w23/18	(l)	W/W	-	5,55	-	-	4,90	-	-	5,05	-	-	4,80	-	
	Cooling power (fancoils)	a35 - w12/7	(m)	kW	2,52	4,70	5,77	3,75	7,00	8,59	3,97	7,40	9,08	4,40	8,20	10,06	
	EER (fancoils)	a35 - w12/7	(m)	W/W	-	3,45	-	-	3,00	-	-	3,38	-	-	3,30	-	
	Energy efficiency class in water heating 35°C	Warmer Climate				A+++			A+++			A+++			A+++		
	SCOP	Warmer Climate				6,46			6,57			6,99			7,09		
	s (Seasonal efficiency for space heating)	Warmer Climate	ηs %			255,4%			259,8%			276,6%			280,5%		
	Energy efficiency class in water heating 35°C	Average Climate				A+++			A+++			A+++			A+++		
	SCOP	Average Climate				4,85			4,95			5,22			5,20		
	s (Seasonal efficiency for space heating)	Average Climate	ηs %			191,0%			195,0%			205,6%			204,8%		
	Energy efficiency class in water heating 35°C	Cold Climate				A++			A++			A++			A++		
	SCOP	Cold Climate				4,06			4,21			4,33			4,32		
s (Seasonal efficiency for space heating)	Cold Climate	ηs %			159,5%			165,3%			170,0%			169,8%			
Energy efficiency class in water heating 55°C	Warmer Climate				A+++			A+++			A+++			A+++			
SCOP	Warmer Climate				4,15			4,21			4,51			4,62			
s (Seasonal efficiency for space heating)	Warmer Climate	ηs %			163,1%			165,4%			177,2%			181,7%			
Energy efficiency class in water heating 55°C	Average Climate				A++			A++			A++			A++			
SCOP	Average Climate				3,31			3,52			3,37			3,47			
s (Seasonal efficiency for space heating)	Average Climate	ηs %			129,5%			137,9%			131,6%			135,7%			
Energy efficiency class in water heating 55°C	Cold Climate				A+			A+			A+			A+			
SCOP	Cold Climate				2,63			2,85			2,88			2,99			
s (Seasonal efficiency for space heating)	Cold Climate	ηs %			102,1%			111,1%			112,1%			116,5%			
Indoor unit sound power (reg. EU 811-2013/UNI EN 12102:2022)				dB(A)	46/40			46/40			46/42			46/42			
Indoor unit sound pressure (reg. EU 811-2013/UNI EN 12102:2022)	(n)			dB(A)	38/32			38/32			38/36			38/36			
Outdoor unit sound power (reg. EU 811-2013/UNI EN 12102:2022)				dB(A)	56/52			58/53			59/54			60/55			
Outdoor unit sound pressure (reg. EU 811-2013/UNI EN 12102:2022)	(o)			dB(A)	36/32			38/33			39/34			40/35			
System circulator absorption				W	3 - 87			3 - 87			3 - 87			3 - 87			
Supply voltage outdoor unit				V/ph/Hz	220-240/1/50			220-240/1/50			220-240/1/50			220-240/1/50			
Maximum current absorbed indoor unit with additional active heating elements				A	18,00			18,00			18,00			18,00			
Maximum power absorbed indoor unit with additional active heating elements				kW	4,05			4,05			4,05			4,05			
Additional electric heating elements				kW	1,5+1,5			1,5+1,5			1,5+1,5			1,5+1,5			
Supply voltage outdoor unit				V/ph/Hz	220-240/1/50			220-240/1/50			220-240/1/50			220-240/1/50			
Outdoor unit maximum absorbed current				A	10			11			14			16			
Outdoor unit maximum absorbed power				kW	2,2			2,6			3,3			3,6			
Compressor type					Twin Rotary DC Inverter			Twin Rotary DC Inverter			Twin Rotary DC Inverter			Twin Rotary DC Inverter			
Refrigerant inlet connection diameter				"	1/4"-5/8"			1/4"-5/8"			3/8"-5/8"			3/8"-5/8"			
Coolant gas	(p)				R32			R32			R32			R32			
Global warming potential				GWP	675			675			675			675			
Refrigerant gas charge				kg	1,5			1,5			1,65			1,65			
Additional charge above 15m				g/m	20			20			38			38			
Refrigerant piping length limit				m	2 - 30			2-30			2 - 30			2 - 30			
Refrigerant piping length limit without minimum surface check according to IEC 60335-2-40:2018				m	30			30			20			20			
Hydraulic connections for the technical water system				"	1"			1"			1"			1"			
System technical water expansion tank capacity				l	8			8			8			8			
Load profile according to EN16147					L			L			L			L			
DHW production energy efficiency class	Average Climate				A			A			A			A			
η _{HW} (seasonal production efficiency DHW)	Average Climate			%	106%			106%			86%			86%			
Boiler volume				l	150			150			150			150			
Boiler interior surface material					DD12 glazed steel S235JR			DD12 glazed steel S235JR			DD12 glazed steel S235JR			DD12 glazed steel S235JR			
Heat exchanger in the boiler				m ²	1,5			1,5			1,5			1,5			
Type and thickness of boiler insulation					Hard expanded polyurethane 55 mm			Hard expanded polyurethane 55 mm			Hard expanded polyurethane 55 mm			Hard expanded polyurethane 55 mm			
Specific dispersion				W/K	2			2			2			2			
DHW expansion tank capacity				l	7			7			7			7			
DHW hydraulic connections				"	3/4"			3/4"			3/4"			3/4"			
DHW circuit heating power	w35 - w55	(r)		kW	2,15			2,15			2,15			2,15			
COP DHW circuit	w35 - w55	(r)		W/W	3,12			3,12			3,12			3,12			
DHW circuit heating power	w12 - w55	(s)		kW	1,60			1,60			1,60			1,6			
COP DHW circuit	w12 - w55	(s)		W/W	2,58			2,58			2,58			2,58			
Sound power indoor unit in heating/cooling + DHW circuit				dB(A)	49			49			49			49			
DHW circuit circulator absorption				W	3 - 43			3 - 43			3 - 43			3 - 43			
DHW circuit coolant gas					R134a			R134a			R134a			R134a			
DHW circuit global warming potential				GWP	1430			1430			1430			1430			
DHW circuit coolant gas load				kg	0,35			0,35			0,35			0,35			

ONLY FOR SHERPA AQUADUE TOWER

(a) Heating mode, external air temperature 7°C b.s./6°C b.u., inlet/outlet water temperature 30°C/35°C
 (b) Heating mode, external air temperature 2°C b.s./1°C b.u., inlet/outlet water temperature 30°C/35°C
 (c) Heating mode, external air temperature -7°C b.s./-8°C b.u., inlet/outlet water temperature 30°C/35°C
 (d) Heating mode, external air temperature -15°C b.s./-16°C b.u., inlet/outlet water temperature 30°C/35°C
 (e) Heating mode, external air temperature 7°C b.s./6°C b.u., inlet/outlet water temperature 40°C/45°C
 (f) Heating mode, external air temperature 2°C b.s./1°C b.u., inlet/outlet water temperature 40°C/45°C
 (g) Heating mode, external air temperature -7°C b.s./-8°C b.u., inlet/outlet water temperature 40°C/45°C
 (h) Heating mode, external air temperature -15°C b.s./-16°C b.u., inlet/outlet water temperature 40°C/45°C
 (i) Cooling mode, external air temperature 35°C, inlet/outlet water temperature 23°C/18°C
 (m) Cooling mode, external air temperature 35°C, inlet/outlet water temperature 12°C/7°C
 (n) Sound pressure values measured at a distance of 1 m in a semi-anechoic chamber
 (o) Sound pressure values measured at a distance of 4 m in free field distance
 (p) Non-air-tightly sealed equipment containing fluorinated GAS
 (q) maximum length of the refrigeration pipes beyond which checks on the minimum surface of the installation rooms are necessary, check the technical manual
 (r) Heating circuit water temperature 35°C/Outlet water temperature 55°C
 (s) Heating circuit water temperature 12°C/Outlet water temperature 55°C
 (t) Non-hermetically sealed equipment containing fluorinated GAS

SINGLE-PHASE R32 TECHNICAL DATA

				T2			T4			T6				
ODU Sherpa S3 E				02288			02289			02290				
IDU Sherpa Aquadue S3 E				02297			02297			02297				
IDU Sherpa Aquadue Tower S3 E				02299			02299			02299				
Compressor frequency				Minimum	Nominal	Maximum	Minimum	Nominal	Maximum	Minimum	Nominal	Maximum		
PUNCTUAL PERFORMANCE	Heating power	a7/6 - w30/35	(a)	kW	5,65	12,10	15,79	6,77	14,50	18,92	7,47	16,00	20,88	
	COP	a7/6 - w30/35	(a)	W/W	-	4,95	-	-	4,70	-	-	4,50	-	
	Heating power	a2/1 - w30/35	(b)	kW	4,34	9,30	12,14	5,32	11,40	14,88	6,07	13,00	16,96	
	COP	a2/1 - w30/35	(b)	W/W	-	3,95	-	-	3,65	-	-	3,50	-	
	Heating power	a-7/8 - w30/35	(c)	kW	4,67	10,00	13,05	5,60	12,00	15,66	6,21	13,3	17,35	
	COP	a-7/8 - w30/35	(c)	W/W	-	3,00	-	-	2,80	-	-	2,70	-	
	Heating power	a-15/16 - w30/35	(d)	kW	3,43	7,35	9,59	3,71	7,94	10,36	4,37	9,35	12,20	
	COP	a-15/16 - w30/35	(d)	W/W	-	2,88	-	-	2,85	-	-	2,66	-	
	Heating power (fancoils)	a7/6 - w40/45	(f)	kW	5,74	12,30	16,05	6,63	14,20	18,53	7,47	16,00	20,88	
	COP (fancoils)	a7/6 - w40/45	(f)	W/W	-	3,80	-	-	3,65	-	-	3,60	-	
	Heating power (fancoils)	a2/1 - w40/45	(g)	kW	5,00	10,70	13,96	5,46	11,70	15,27	5,98	12,80	16,70	
	COP (fancoils)	a2/1 - w40/45	(g)	W/W	-	3,00	-	-	2,86	-	-	2,85	-	
	Heating power (fancoils)	a-7/8 - w40/45	(h)	kW	4,76	10,20	13,31	5,51	11,80	15,40	6,02	12,90	16,83	
	COP (fancoils)	a-7/8 - w40/45	(h)	W/W	-	2,40	-	-	2,35	-	-	2,23	-	
	Heating power (fancoils)	a-15/16 - w40/45	(i)	kW	3,10	6,63	8,65	3,34	7,16	9,34	3,93	8,41	10,97	
	COP (fancoils)	a-15/16 - w40/45	(i)	W/W	-	2,32	-	-	2,29	-	-	2,03	-	
	Cooling power	a35 - w23/18	(l)	kW	5,60	12,00	14,29	6,31	13,00	16,08	6,96	13,50	17,75	
	EER	a35 - w23/18	(l)	W/W	-	4,00	-	-	3,70	-	-	3,61	-	
	Cooling power (fancoils)	a35 - w12/7	(m)	kW	5,42	11,60	13,82	5,93	12,70	15,13	6,54	14,00	16,67	
	EER (fancoils)	a35 - w12/7	(m)	W/W	-	2,75	-	-	2,55	-	-	2,45	-	
EFFICIENCIES	Energy efficiency class in water heating 35°C	Warmer Climate			A+++			A+++			A+++			
	SCOP	Warmer Climate			6,48			6,58			6,47			
	s (Seasonal efficiency for space heating)	Warmer Climate	ηs %		256,1%			260,3%			255,6%			
	Energy efficiency class in water heating 35°C	Average Climate			A+++			A+++			A+++			
	SCOP	Average Climate			4,81			4,72			4,62			
	s (Seasonal efficiency for space heating)	Average Climate	ηs %		189,4%			185,7%			181,7%			
	Energy efficiency class in water heating 35°C	Cold Climate			A+			A++			A++			
	SCOP	Cold Climate			4,08			4,07			4,02			
	s (Seasonal efficiency for space heating)	Cold Climate	ηs %		160,2%			159,6%			157,8%			
	Energy efficiency class in water heating 55°C	Warmer Climate			A+++			A+++			A+++			
	SCOP	Warmer Climate			4,43			4,49			4,48			
	s (Seasonal efficiency for space heating)	Warmer Climate	ηs %		174,1%			176,5%			176,1%			
	Energy efficiency class in water heating 55°C	Average Climate			A++			A++			A++			
	SCOP	Average Climate			3,45			3,47			3,41			
	s (Seasonal efficiency for space heating)	Average Climate	ηs %		135,1%			135,6%			133,3%			
	Energy efficiency class in water heating 55°C	Cold Climate			A+			A+			A+			
	SCOP	Cold Climate			3,02			3,05			3,12			
	s (Seasonal efficiency for space heating)	Cold Climate	ηs %		117,8%			118,9%			121,8%			
	NOISE LEVEL	Indoor unit sound power (reg. EU 811-2013/UNI EN 12102:2022)			dB(A)	48/46			48/46			48/46		
		Indoor unit sound pressure (reg. EU 811-2013/UNI EN 12102:2022)		(n)	dB(A)	40/38			40/38			40/38		
Outdoor unit sound power (reg. EU 811-2013/UNI EN 12102:2022)				dB(A)	64/60			65/62			68/64			
Outdoor unit sound pressure (reg. EU 811-2013/UNI EN 12102:2022)			(o)	dB(A)	44/40			45/42			48/44			
ELECTRICAL DATA	System circulator absorption			W	8 - 140			8 - 140			8 - 140			
	Supply voltage indoor unit			V/ph/Hz	220-240/1/50			220-240/1/50			220-240/1/50			
	Maximum current absorbed indoor unit with additional active heating elements			A	31,0			31,0			31			
	Maximum power absorbed indoor unit with additional active heating elements			kW	7,05			7,05			7,05			
	Additional electric heating elements			kW	3,0+3,0			3,0+3,0			3,0+3,0			
	Supply voltage outdoor unit			V/ph/Hz	220-240/1/50			220-240/1/50			220-240/1/50			
	Outdoor unit maximum absorbed current			A	23			25			25			
	Outdoor unit maximum absorbed power			kW	5,4			5,7			5,7			
	Compressor type				Twin Rotary DC Inverter			Twin Rotary DC Inverter			Twin Rotary DC Inverter			
	Refrigerant inlet connection diameter			"	3/8"-5/8"			3/8"-5/8"			3/8"-5/8"			
COOLING CIRCUIT	Coolant gas		(p)		R32			R32			R32			
	Global warming potential			GWP	675			675			675			
	Refrigerant gas charge			kg	1,84			1,84			1,84			
	Additional charge above 15m			g/m	38			38			38			
	Refrigerant piping length limit	min - max		m	2 - 30			2 - 30			2 - 30			
	Refrigerant piping length limit without minimum surface check according to IEC 60335-2-40:2018	max	(q)	m	15			15			15			
	Hydraulic connections for the technical water system			"	1"			1"			1"			
	System technical water expansion tank capacity			l	8			8			8			
	Load profile according to EN16147				L			L			L			
	DHW production energy efficiency class	Average Climate			A			A			A			
HYDRAULIC DATA	ηHW (seasonal production efficiency DHW)	Average Climate		%	81%			81%			81%			
	Boiler volume			l	150			150			150			
	Boiler interior surface material				DD12 glazed steel S235JR			DD12 glazed steel S235JR			DD12 glazed steel S235JR			
	Heat exchanger in the boiler			m²	1,5			1,5			1,5			
	Type and thickness of boiler insulation				Hard expanded polyurethane 55 mm			Hard expanded polyurethane 55 mm			Hard expanded polyurethane 55 mm			
	Specific dispersion			W/K	2			2			2			
	DHW expansion tank capacity			l	7			7			7			
	DHW hydraulic connections			"	3/4"			3/4"			3/4"			
	DHW circuit heating power	w35 - w55	(r)	kW	2,15			2,15			2,15			
	COP DHW circuit	w35 - w55	(r)	W/W	3,12			3,12			3,12			
INTEGRATED DHW BOILER	DHW circuit heating power	w12 - w55	(s)	kW	1,60			1,60			1,60			
	COP DHW circuit	w12 - w55	(s)	W/W	2,58			2,58			2,58			
	Sound power indoor unit in heating/cooling + DHW circuit			dB(A)	49			49			49			
	DHW circuit circulator absorption			W	3 - 43			3 - 43			3 - 43			
	DHW circuit coolant gas		(t)		R134a			R134a			R134a			
	DHW circuit global warming potential			GWP	1430			1430			1430			
	DHW circuit coolant gas load			kg	0,35			0,35			0,35			
	SECONDARY DHW COOLING CIRCUIT	Heating mode, external air temperature 7°C b.s./6°C b.u., inlet/outlet water temperature 30°C/35°C				2,15			2,15			2,15		
		Heating mode, external air temperature 2°C b.s./1°C b.u., inlet/outlet water temperature 30°C/35°C				2,15			2,15			2,15		
		Heating mode, external air temperature -7°C b.s./-8°C b.u., inlet/outlet water temperature 30°C/35°C				2,15			2,15			2,15		
Heating mode, external air temperature -15°C b.s./-16°C b.u., inlet/outlet water temperature 30°C/35°C					2,15			2,15			2,15			
Heating mode, external air temperature 7°C b.s./6°C b.u., inlet/outlet water temperature 40°C/45°C					2,15			2,15			2,15			
Heating mode, external air temperature 2°C b.s./1°C b.u., inlet/outlet water temperature 40°C/45°C					2,15			2,15			2,15			
Heating mode, external air temperature -7°C b.s./-8°C b.u., inlet/outlet water temperature 40°C/45°C					2,15			2,15			2,15			
Heating mode, external air temperature -15°C b.s./-16°C b.u., inlet/outlet water temperature 40°C/45°C					2,15			2,15			2,15			
Cooling mode, external air temperature 35°C, inlet/outlet water temperature 23°C/18°C					0,35			0,35			0,35			
Cooling mode, external air temperature 35°C, inlet/outlet water temperature 12°C/7°C					0,35			0,35			0,35			

(a) Heating mode, external air temperature 7°C b.s./6°C b.u., inlet/outlet water temperature 30°C/35°C
 (b) Heating mode, external air temperature 2°C b.s./1°C b.u., inlet/outlet water temperature 30°C/35°C
 (c) Heating mode, external air temperature -7°C b.s./-8°C b.u., inlet/outlet water temperature 30°C/35°C
 (d) Heating mode, external air temperature -15°C b.s./-16°C b.u., inlet/outlet water temperature 30°C/35°C
 (e) Heating mode, external air temperature 7°C b.s./6°C b.u., inlet/outlet water temperature 40°C/45°C
 (f) Heating mode, external air temperature 2°C b.s./1°C b.u., inlet/outlet water temperature 40°C/45°C
 (g) Heating mode, external air temperature -7°C b.s./-8°C b.u., inlet/outlet water temperature 40°C/45°C
 (h) Heating mode, external air temperature -15°C b.s./-16°C b.u., inlet/outlet water temperature 40°C/45°C
 (i) Cooling mode, external air temperature 35°C, inlet/outlet water temperature 23°C/18°C
 (m) Cooling mode, external air temperature 35°C, inlet/outlet water temperature 12°C/7°C
 (n) Sound pressure values measured at a distance of 1 m in a semi-anechoic chamber
 (o) Sound pressure values measured at a distance of 4 m in free field distance
 (p) Non-air-tightly sealed equipment containing fluorinated GAS
 (q) maximum length of the refrigeration pipes beyond which checks on the minimum surface of the installation rooms are necessary, check the technical manual
 (r) Heating circuit water temperature 35°C/Outlet water temperature 55°C
 (s) Heating circuit water temperature 12°C/Outlet water temperature 55°C
 (t) Non-hermetically sealed equipment containing fluorinated GAS

ONLY FOR SHERPA AQUADUE TOWER

BMS

HEAT PUMPS

FAN COIL UNITS

HRV

UNICO

FIXED AIR CONDITIONERS

PORTABLES

THREE-PHASE R32 TECHNICAL DATA

				12T			14T			16T				
ODU Sherpa S3 E				02291			02292			02293				
IDU Sherpa Aquadue S3 E				02297			02297			02297				
IDU Sherpa Aquadue Tower S3 E				02299			02299			02299				
Compressor frequency				Minimum	Nominal	Maximum	Minimum	Nominal	Maximum	Minimum	Nominal	Maximum		
PUNCTUAL PERFORMANCE	Heating power	a7/6 - w30/35	(a)	kW	5,65	12,10	15,79	6,77	14,50	18,92	7,47	16,00	20,88	
	COP	a7/6 - w30/35	(a)	W/W	-	4,95	-	-	4,70	-	-	4,50	-	
	Heating power	a2/1 - w30/35	(b)	kW	4,34	9,30	12,14	5,32	11,40	14,88	6,07	13,00	16,96	
	COP	a2/1 - w30/35	(b)	W/W	-	3,95	-	-	3,65	-	-	3,50	-	
	Heating power	a-7/-8 - w30/35	(c)	kW	4,67	10,00	13,05	5,60	12,00	15,66	6,21	13,30	17,35	
	COP	a-7/-8 - w30/35	(c)	W/W	-	3,00	-	-	2,80	-	-	2,70	-	
	Heating power	a-15/-16 - w30/35	(d)	kW	3,43	7,35	9,59	3,71	7,94	10,36	4,37	9,35	12,20	
	COP	a-15/-16 - w30/35	(d)	W/W	-	2,88	-	-	2,85	-	-	2,66	-	
	Heating power (fancoils)	a7/6 - w40/45	(f)	kW	5,74	12,30	16,05	6,63	14,20	18,53	7,47	16,00	20,88	
	COP (fancoils)	a7/6 - w40/45	(f)	W/W	-	3,80	-	-	3,65	-	-	3,60	-	
	Heating power (fancoils)	a2/1 - w40/45	(g)	kW	5,00	10,70	13,96	5,46	11,70	15,27	5,98	12,80	16,70	
	COP (fancoils)	a2/1 - w40/45	(g)	W/W	-	3,00	-	-	2,86	-	-	2,85	-	
	Heating power (fancoils)	a-7/-8 - w40/45	(h)	kW	4,76	10,20	13,31	5,51	11,80	15,40	6,02	12,90	16,83	
	COP (fancoils)	a-7/-8 - w40/45	(h)	W/W	-	2,40	-	-	2,35	-	-	2,23	-	
	Heating power (fancoils)	a-15/-16 - w40/45	(i)	kW	3,10	6,63	8,65	3,34	7,16	9,34	3,93	8,41	10,97	
	COP (fancoils)	a-15/-16 - w40/45	(i)	W/W	-	2,32	-	-	2,29	-	-	2,03	-	
	Cooling power	a35 - w23/18	(l)	kW	5,60	12,00	14,29	6,31	13,00	16,08	6,96	13,50	17,75	
	EER	a35 - w23/18	(l)	W/W	-	4,00	-	-	3,70	-	-	3,61	-	
	Cooling power (fancoils)	a35 - w12/7	(m)	kW	5,42	11,60	13,82	5,93	12,70	15,13	6,54	14,00	16,67	
	EER (fancoils)	a35 - w12/7	(m)	W/W	-	2,75	-	-	2,55	-	-	2,45	-	
	Energy efficiency class in water heating 35°C	Warmer Climate				A+++			A+++			A+++		
	SCOP	Warmer Climate				6,47			6,57			6,28		
	s (Seasonal efficiency for space heating)	Warmer Climate	ηs %			255,6%			259,8%			248,1%		
	Energy efficiency class in water heating 35°C	Average Climate				A+++			A+++			A+++		
SCOP	Average Climate				4,81			4,72			4,62			
s (Seasonal efficiency for space heating)	Average Climate	ηs %			189,3%			185,6%			181,6%			
Energy efficiency class in water heating 35°C	Cold Climate				A++			A++			A++			
SCOP	Cold Climate				4,08			4,07			4,02			
s (Seasonal efficiency for space heating)	Cold Climate	ηs %			160,2%			159,6%			157,8%			
Energy efficiency class in water heating 55°C	Warmer Climate				A+++			A+++			A+++			
SCOP	Warmer Climate				4,42			4,49			4,47			
s (Seasonal efficiency for space heating)	Warmer Climate	ηs %			173,8%			176,4%			175,9%			
Energy efficiency class in water heating 55°C	Average Climate				A++			A++			A++			
SCOP	Average Climate				3,45			3,47			3,41			
s (Seasonal efficiency for space heating)	Average Climate	ηs %			135,1%			135,6%			133,2%			
Energy efficiency class in water heating 55°C	Cold Climate				A+			A+			A+			
SCOP	Cold Climate				3,02			3,05			3,12			
s (Seasonal efficiency for space heating)	Cold Climate	ηs %			117,7%			118,9%			121,8%			
Indoor unit sound power (reg. EU 811-2013/UNI EN 12102:2022)				dB(A)	48/46			48/46			48/46			
Indoor unit sound pressure (reg. EU 811-2013/UNI EN 12102:2022)		(n)		dB(A)	40/38			40/38			40/38			
Outdoor unit sound power (reg. EU 811-2013/UNI EN 12102:2022)				dB(A)	64/60			65/62			68/64			
Outdoor unit sound pressure (reg. EU 811-2013/UNI EN 12102:2022)		(o)		dB(A)	44/40			45/42			48/44			
System circulator absorption				W	8 - 140			8 - 140			8 - 140			
Supply voltage indoor unit				V/ph/Hz	220-240/1/50			220-240/1/50			220-240/1/50			
Maximum current absorbed indoor unit with additional active heating elements				A	31			31			31			
Maximum power absorbed indoor unit with additional active heating elements				kW	7,05			7,05			7,05			
Additional electric heating elements				kW	3,0+3,0			3,0+3,0			3,0+3,0			
Supply voltage outdoor unit				V/ph/Hz	380-415/3/50			380-415/3/50			380-415/3/50			
Outdoor unit maximum absorbed current				A	8			8			8			
Outdoor unit maximum absorbed power				kW	5,4			5,7			5,7			
Compressor type					Twin Rotary DC Inverter			Twin Rotary DC Inverter			Twin Rotary DC Inverter			
Refrigerant inlet connection diameter				"	3/8"-5/8"			3/8"-5/8"			3/8"-5/8"			
Coolant gas		(p)			R32			R32			R32			
Global warming potential				GWP	675			675			675			
Refrigerant gas charge				kg	1,84			1,84			1,84			
Additional charge above 15m				g/m	38			38			38			
Refrigerant piping length limit				m	2 - 30			2 - 30			2 - 30			
Refrigerant piping length limit without minimum surface check according to IEC 60335-2-40:2018				m	15			15			15			
Hydraulic connections for the technical water system				"	1"			1"			1"			
System technical water expansion tank capacity				l	8			8			8			
Load profile according to EN16147				L	L			L			L			
DHW production energy efficiency class	Average Climate				A			A			A			
η _{HW} (seasonal production efficiency DHW)	Average Climate	%			81%			81%			81%			
Boiler volume				l	150			150			150			
Boiler interior surface material					DD12 glazed steel S235JR			DD12 glazed steel S235JR			DD12 glazed steel S235JR			
Heat exchanger in the boiler				m ²	1,5			1,5			1,5			
Type and thickness of boiler insulation					Hard expanded polyurethane 55 mm			Hard expanded polyurethane 55 mm			Hard expanded polyurethane 55 mm			
Specific dispersion				W/K	2			2			2			
DHW expansion tank capacity				l	7			7			7			
DHW hydraulic connections				"	3/4"			3/4"			3/4"			
DHW circuit heating power	w35 - w55	(r)		kW	2,15			2,15			2,15			
COP DHW circuit	w35 - w55	(r)		W/W	3,12			3,12			3,12			
DHW circuit heating power	w12 - w55	(s)		kW	1,60			1,60			1,60			
COP DHW circuit	w12 - w55	(s)		W/W	2,58			2,58			2,58			
Sound power indoor unit in heating/cooling + DHW circuit				dB(A)	49			49			49			
DHW circuit circulator absorption				W	3 - 43			3 - 43			3 - 43			
DHW circuit coolant gas					R134a			R134a			R134a			
DHW circuit global warming potential				GWP	1430			1430			1430			
DHW circuit coolant gas load				kg	0,35			0,35			0,35			

(a) Heating mode, external air temperature 7°C b.s./6°C b.u., inlet/outlet water temperature 30°C/35°C
 (b) Heating mode, external air temperature 2°C b.s./1°C b.u., inlet/outlet water temperature 30°C/35°C
 (c) Heating mode, external air temperature -7°C b.s./-8°C b.u., inlet/outlet water temperature 30°C/35°C
 (d) Heating mode, external air temperature -15°C b.s./-16°C b.u., inlet/outlet water temperature 30°C/35°C
 (e) Heating mode, external air temperature 7°C b.s./6°C b.u., inlet/outlet water temperature 40°C/45°C
 (f) Heating mode, external air temperature 2°C b.s./1°C b.u., inlet/outlet water temperature 40°C/45°C
 (g) Heating mode, external air temperature -7°C b.s./-8°C b.u., inlet/outlet water temperature 40°C/45°C
 (h) Heating mode, external air temperature -15°C b.s./-16°C b.u., inlet/outlet water temperature 40°C/45°C
 (i) Heating mode, external air temperature 7°C b.s./6°C b.u., inlet/outlet water temperature 23°C/18°C
 (l) Cooling mode, external air temperature 35°C, inlet/outlet water temperature 23°C/18°C

(m) Cooling mode, external air temperature 35°C, inlet/outlet water temperature 12°C/7°C
 (n) Sound pressure values measured at a distance of 1 m in a semi-anechoic chamber
 (o) Sound pressure values measured at a distance of 4 m in free field distance
 (p) Non-air/tightly sealed equipment containing fluorinated GAS
 (q) maximum length of the refrigeration pipes beyond which checks on the minimum surface of the installation rooms are necessary, check the technical manual
 (r) Heating circuit water temperature 35°C/Outlet water temperature 55°C
 (s) Heating circuit water temperature 12°C/Outlet water temperature 55°C
 (t) Non-hermetically sealed equipment containing fluorinated GAS

		4			6			8			10			
		Cooling w7 - a35	DHW w65 - w12	Cooling w7 - A35 DHW w65 - w12	Cooling w7 - a35	DHW w65 - w12	Cooling w7 - A35 DHW w65 - w12	Cooling w7 - a35	DHW w65 - w12	Cooling w7 - A35 DHW w65 - w12	Cooling w7 - a35	DHW w65 - w12	Cooling w7 - A35 DHW w65 - w12	
First circuit + second circuit data	Cooling capacity	kw	4.70	0.64	4.70	7.00	0.64	7.00	7.40	0.64	7.40	8.20	0.64	8.20
	DHW yield	kw	0.00	1,28	1,28	0.00	1,28	1,28	0.00	1,28	1,28	0.00	1,28	1,28
	Absorption	kw	1.36	0.56	1.17	2.33	0.56	2.00	2.19	0.56	1.87	2.48	0.56	2.13
	EER COP		3.45	2.30	4.03	3.00	2.30	3.50	3.38	2.30	3.95	3.30	2.30	3.85

		12			14			16			12T			14T			16T			
		Cooling w7 - a35	DHW w65 - w12	Cooling w7 - A35 DHW w65 - w12	Cooling w7 - a35	DHW w65 - w12	Cooling w7 - A35 DHW w65 - w12	Cooling w7 - a35	DHW w65 - w12	Cooling w7 - A35 DHW w65 - w12	Cooling w7 - a35	DHW w65 - w12	Cooling w7 - A35 DHW w65 - w12	Cooling w7 - a35	DHW w65 - w12	Cooling w7 - A35 DHW w65 - w12	Cooling w7 - a35	DHW w65 - w12	Cooling w7 - A35 DHW w65 - w12	
First circuit + second circuit data	Cooling capacity	kw	11.60	0.64	11.60	12.70	0.64	12.70	14.00	0.64	14.00	11.60	0.64	11.60	12.70	0.64	12.70	14.00	0.64	14.00
	DHW yield	kw	0.00	1.28	1.28	0.00	1.28	1.28	0.00	1.28	1.28	0.00	1.28	1.28	0.00	1.28	1.28	0.00	1.28	1.28
	Absorption	kw	4.22	0.56	3.61	4.98	0.56	4.26	5.71	0.56	4.89	4.22	0.56	3.61	4.98	0.56	4.26	5.71	0.56	4.89
	EER COP		2.75	2.30	3.21	2.55	2.30	2.98	2.45	2.30	2.86	2.75	2.30	3.21	2.55	2.30	2.98	2.45	2.30	2.86

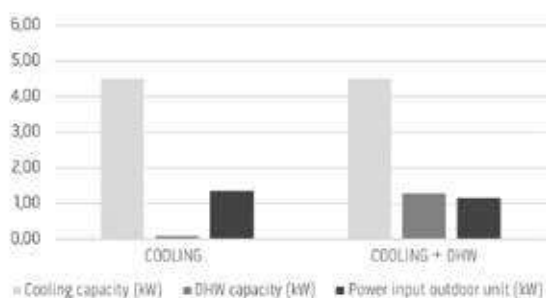

COOLING + DHW WITH ENERGY RECOVERY

During summer operation in cooling mode, the cycle dedicated to DHW production extracts heat from return water from the system circuit.

The cooling requirements of the building is partially satisfied by the DHW cycle and the comfort refrigerating cycle must deliver less power by reducing the speed of the inverter compressor.

The heat taken from the system is recovered in hot water for domestic use. The efficiency of the integrated system increases (ratio between the energy produced and the energy absorbed from the mains).

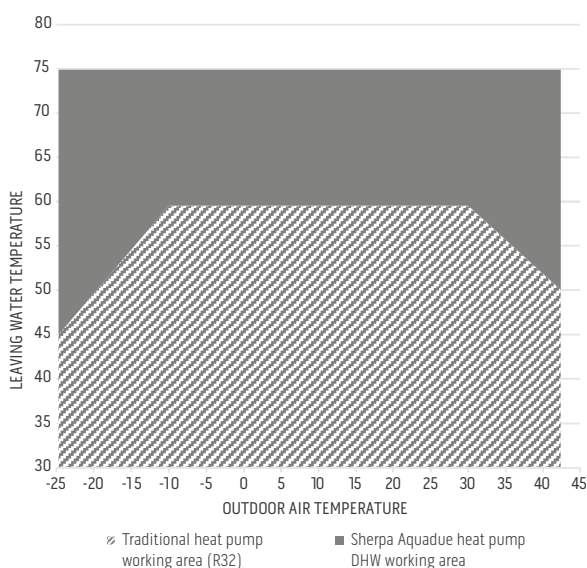

PERFORMANCE AND ENERGY ADVANTAGES

In adverse weather conditions traditional heat pumps decrease thermal output producing water at a lower temperature. Sherpa AQUADUE® as well as extending the area of operation ensures a constant heat output, in the production of Domestic Hot Water. The double refrigerator circuit allows higher DHW production temperatures thanks to the water-water circuit which are independent of outside air temperature. In summer cooling operation the refrigeration cycle dedicated to DHW production removes heat from the comfort circuit increasing the overall efficiency of the system.

ACCESSORIES

			suspended	tower
CONTROLS	B0916	Kit 3-way valve for DHW	●	●
	B0623	Outdoor air temperature probe kit	●	●
	B0624	Kit DHW storage tank sensor	●	●
	B0931	Remote control display kit 10 m	○	○
OTHER	B0918	Kit Sherpa Flex Box AS	≤10	—
	B0961	Kit Sherpa Flex Box AS RAL 9016	≤10	—
STORAGE TANKS / PUFFER	O1804	HE 200 L storage tank	○	—
	O1805	HE 300 L storage tank	○	—
	O1806	HES 300 L solar storage tank	○	—
	O1807	Hybride boiler HY 300 L	○	—
	O1808	HYS 300 L solar hybrid storage tank	○	—
	O1199	Thermal accumulation 50 L	○	○
O1200	Thermal accumulation 100 L	○	○	

○ Optional accessory | ● Standard accessory | — Accessory not compatible

Accessory description on page 56

Please note that optional accessories are available for purchase with all models of the heat pump. When compatibility is only possible with certain sizes, the information is shown in the table. Standard accessories are already included in the heat pump code.